



ORCHID SEED & TISSUE CULTURE MEDIA RECOMMENDATION GUIDE

PhytoTechnology Laboratories offers several media specifically developed for the *in vitro* culture of orchids. These media range from basic seed sowing media to media for clonal propagation (mericloning) and stem propagation. We offer media that are composed of basic mineral salts, which must be supplemented with other components before use, as well as media that are complete and require only the addition of water. All of our media are manufactured according to cGMP standards in our environmentally controlled manufacturing facility in Lenexa, Kansas. Each medium is tested for physio-chemical specifications, and then biologically tested with two commercially significant orchid or other plant cell lines. PhytoTechnology Laboratories is committed to maintaining inventory of its entire plant tissue culture product line.



Some features of our manufactured media include:

- All media components meet USP or ACS quality standards, where applicable
- PhytoTechnology Laboratories has the capacity to manufacture up to 10,000 liters of certain orchid media
- Using powder media simplifies media production and reduces technician error when preparing media
- PhytoTechnology Laboratories offers complete orchid media, which only require the addition of water to prepare
- Powdered media has a shelf life of 3 years
- PhytoTechnology Laboratories offers secure on-line ordering with no minimum order requirements
- Most orders are shipped within 48 hours of receipt of the order

Have you questioned which orchid medium will work best for your application?

PhytoTechnology Laboratories has prepared the following tables to help with the selection process:

TERRESTRIAL ORCHID MEDIA SELECTION GUIDE

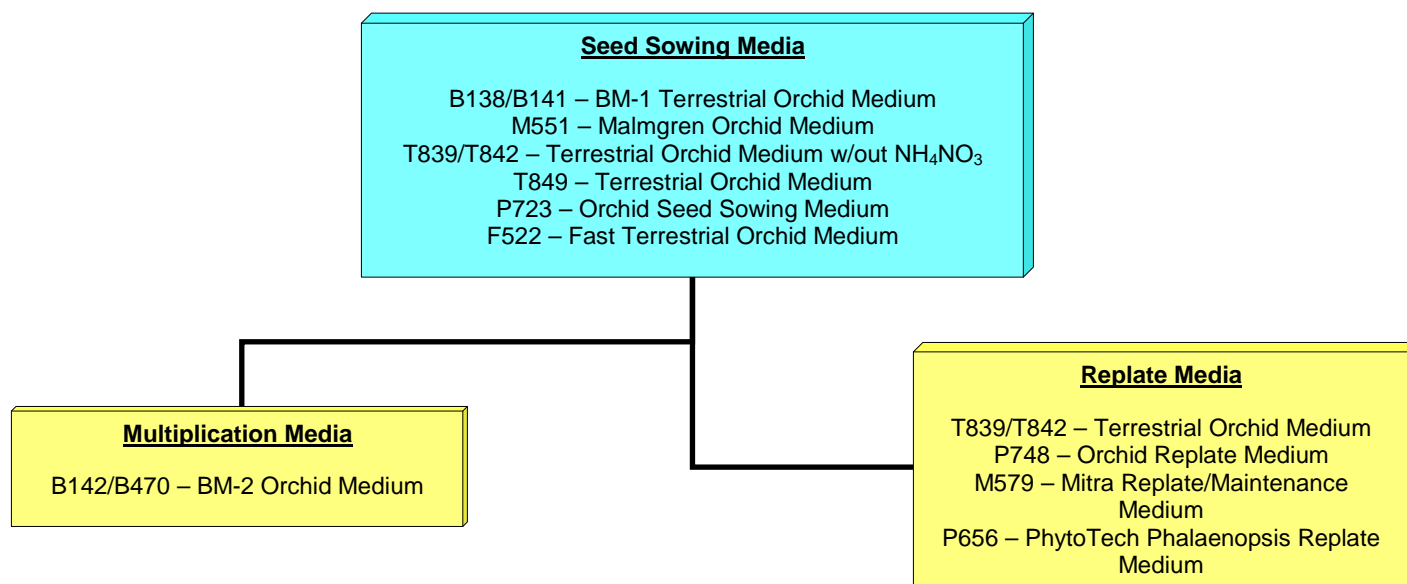

PhytoTechnology Laboratories®

PO Box 12205; Shawnee Mission, KS 66282-2205

Phone: 1-888-749-8682 or 1-913-341-5343; Fax: 1-888-449-8682 or 1-913-341-5442

Web Site: www.phytotechlab.com

© 2009 PhytoTechnology Laboratories®

Terrestrial Orchid Media Selection by Genus

Genus	Germination Medium/Media	Replate Medium/Media	Multiplication Medium
<i>Aplectrum</i>	K400	K400, K425	
<i>Arethusa</i>	K400, P723	K400, K425, P748	
<i>Bletia</i>	B138/B141, K400, P723, V895	P748, V895	
<i>Bletilla</i>	P668 ¹ , P723	P668, P748	O753
<i>Calopogon</i>	K400, P723	P723, P748	
<i>Calypso</i>	B138/B141, B142/B470, F522	F522	
<i>Coeloglossum</i>	K400	K400, K425, P748	
<i>Cypripedium</i>	B142/B470 ² , F522, K400 ^{1,2} , M551 ³ , T839 ² , T842 ² , T849 ²	B138/B141, F522, K400 ^{1,2} , P668 ¹ , T849	O753
<i>Dactylorhiza</i>	F522	F522, P748	
<i>Epipactis</i>	B142/B470	B138/B141, P668	
<i>Eulophia</i>	P723, V895	P748, V895	
<i>Goodyera</i>	M551, P668 ¹ , P723	P748	
<i>Gymnadenia</i>	F522, M551, P668 ¹	F522, M551, P748	
<i>Limodorum</i>	B142	B142	
<i>Liparis</i>	K400	K400, K425, P748	
<i>Oeceoclades</i>	P668 ¹ , P723, V895	P723, V895	
<i>Ophrys</i>	M551	M551	
<i>Orchis</i>	F522, M551, P668 ¹	F552, M551	
<i>Paphiopedilum</i>	P668 ^{1,2}	P668 ¹ , P668	
<i>Phragmipedium</i>	P668 ^{1,2}	P668 ¹ , P668	
<i>Platanthera</i>	F522, K400, L472, M551, P668 ¹ , P723	F552, M551, P723, P748	
<i>Pogonia</i>	K400	K400	
<i>Habenaria</i>	M551, P723	M551, P748	
<i>Sacoila</i>	K400, M551		
<i>Spathoglottis</i>	P723	P668, P723, P748	O753
<i>Spiranthes</i>	K400, M551, P723	M551, P748	O753
<i>Thelymitra</i>	P723, T839, T842	P748, T839, T842, T849	
<i>Tipularia</i>	K400	K400, K425	
<i>Zeuxine</i>	P723	P723, P748	

¹Medium used at 1/2-strength.

²Medium supplemented with up to 15% coconut water (Product C195).

³Medium supplemented with either 10 g/L sucrose (Product S391) or 5 g/L S391 + 5 g/L glucose (Product G360).

Please see “Media Recommendation Note” at end of this publication for additional information.

PhytoTechnology Laboratories®

PO Box 12205; Shawnee Mission, KS 66282-2205

Phone: 1-888-749-8682 or 1-913-341-5343; Fax: 1-888-449-8682 or 1-913-341-5442

Web Site: www.phytotechlab.com

© 2009 PhytoTechnology Laboratories®

EPIPHYTIC ORCHID MEDIA SELECTION GUIDE

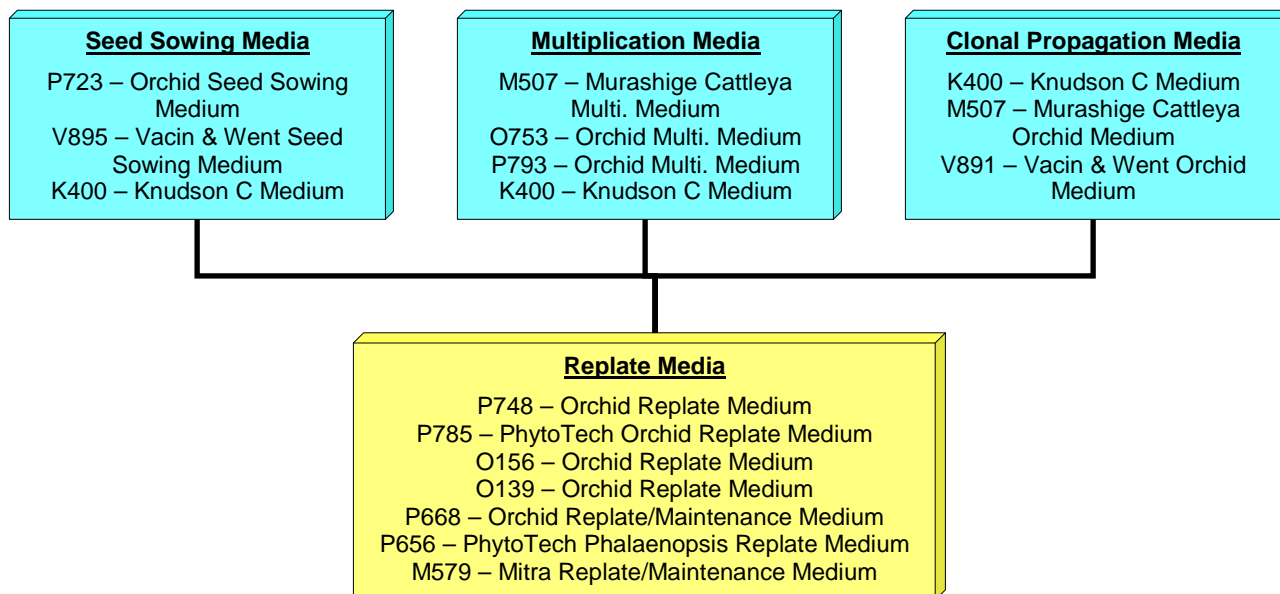

Epiphytic Orchid Media Selection by Genus

Genus	Germination Medium/Media	Replate Medium/Media	Multiplication Medium/Media
<i>Ascocenda</i>	K400, P668 ¹ , P723, P785, V895	O156, P668	M507
<i>Brassia</i>	K400, K425, P723	K425, P748	O753
<i>Cattleya</i>	K400, K425, L472, P668 ¹ , P723, P785, V895	K400, K425, O156 ¹ , P668 ¹ , P748, P785	M507, O753
<i>Cyrtopodium</i>	P723	P723, P748	
<i>Dendrobium</i>	K400, K425, M579, V895	K400, K425, M579, V895	M507, O753
<i>Dendrophylax</i>	P723	P723, P748	
<i>Encyclia</i>	P723, P748	P748	
<i>Epidendrum</i>	K400, K425, M579, P668 ¹ , P723, V895	K400, K425, O156, P668, P748, P785, V895	
<i>Gongora</i>	K425, P723	K425, P748	
<i>Maxillaria</i>	P723	P748	
<i>Oncidium</i>	O156 ¹ , P668 ¹ , P723	O156 ¹ , P668 ¹ , P723, P748	M507, O753
<i>Odontoglossum</i>	K400, K425, O156 ¹ , P723	K400, K425, O156 ¹	
<i>Phalaenopsis</i>	I365, K400, O156, P656, P668 ¹ , P723, P782, P785	I365, O156, P656, P668, P748, P785	M507, O753
<i>Pleurothallis</i>	P668, P668 ¹ , P723	O156, O156 ¹ , P748	
<i>Prosthechea</i>	P723	P723, P748	
<i>Schomburgkia</i>	P723	P723, P748	
<i>Vanda</i>	K400, M579, P723, P785, V895	M579, O156, P723, P748, V895	
<i>Vanilla</i>	K400, K425	K400, K425, V895	

PhytoTechnology Laboratories®

PO Box 12205; Shawnee Mission, KS 66282-2205

Phone: 1-888-749-8682 or 1-913-341-5343; Fax: 1-888-449-8682 or 1-913-341-5442

Web Site: www.phytotechlab.com

© 2009 PhytoTechnology Laboratories®

PhytoTechnology Labs' Orchid Media Family Relations

The following table provides information on how the orchid media in each "family" is related to each other. This guide provides a basic look at how one medium is different from another. In many cases one can be made into another with one supplement. If you **Start With** one medium and make the **Addition or Change** as described it **Creates** the medium listed.

BM Family (BM-1, BM-2)

Start With	Addition or Change	Creates	Application
B138	plus Agar	B141	Developed for seed germination, replate, & multiplication of terrestrial orchids.
B141	plus BA	B142	
B138	plus BA	B470	

Malmgren Family

Start With	Addition or Change	Creates	Application
M482	plus Pineapple Powder	M534	Developed for hardy terrestrial orchids (<i>Cypripedium</i> in particular).
M534	plus Agar	M551	

Maintenance/Replate Family

Start With	Addition or Change	Creates	Application
O139	plus Charcoal	P668	Suitable for replating most epiphytic & terrestrial orchids.
P668	plus Agar	P658	
P668	plus Banana Powder	O156	
O156	plus Agar	P748	

Seed Sowing Family

Start With	Addition or Change	Creates	Application
P727	plus Charcoal	P723	Suitable for germinating most epiphytic & terrestrial orchids.

Slipper Orchid Family

Start With	Addition or Change	Creates	Application
T842	double Casein	T839	Suitable for seed germination & replate of slipper orchids.
T842 & T839	minus Casein; plus Ammonium Nitrate	T849	

Vacin & Went Family

Start With	Addition or Change	Creates	Application
V505	plus Thiamine HCl	V882	Developed for general use in seed germination, replate, & multiplication of most epiphytic orchids.
V882	plus Sucrose	V891	
V891	plus Agar	V895	

Multiplication Family

Start With	Addition or Change	Creates	Application
P793	plus Agar	O753	Suitable for the multiplication of most epiphytic & terrestrial orchids.

Proprietary Replate/Seed Sowing Family

Start With	Addition or Change	Creates	Application
P781	plus Gelling Agent	P782	Suitable for the seed germination, replate, & multiplication of most orchids (particular epiphytic orchids).
P782	plus Banana Powder	P785	

PhytoTech Proprietary Formulations

Product No.	Major Components	Application
K425	Contains Charcoal, Sucrose, Banana Powder, & Gelling Agent	Suitable alternative to K400 for seed germination & replate.
P656	Contains Charcoal, Sucrose, Banana Powder, Potato Powder, & Gelling Agent	Developed for <i>Phalaenopsis</i> seed germination, replate, & tissue culture.

Continued next page

PhytoTechnology Laboratories®

PO Box 12205; Shawnee Mission, KS 66282-2205

Phone: 1-888-749-8682 or 1-913-341-5343; Fax: 1-888-449-8682 or 1-913-341-5442

Web Site: www.phytotechlab.com

© 2009 PhytoTechnology Laboratories®

Unique Formulations

Product No.	Application
F522	Developed for the seed germination & replate of terrestrial orchids, particularly <i>Cypripedium</i> and <i>Calypso</i> .
I365	Originally developed for <i>Phalaenopsis</i> seed germination, replate, & tissue culture.
K400	Original & classic seed germination & replate medium.
L472	Developed as an alternative to K400 for seed germination & tissue culture.
M507	Developed for the culture & multiplication of <i>Cattleya</i> & allies.
M579	Developed for the seed germination & replate of <i>Vanda</i> & allies.

ORCHID SEED GERMINATION

Orchid seeds are very small and contain little food reserves. A single seed capsule may contain 1,500 to 3,000,000 seeds. Sowing the seed *in vitro* makes it possible to germinate immature seed (green pods). It is much easier to sterilize the green capsule than individual seed after the capsule has split open. Lucke (1971) indicated that orchid seed can be sterilized when the capsule is about two-thirds ripe. Listed below are approximate normal ripening times of capsules for various orchid species. Exact capsule ripening times may vary depending on species, hybrid, and growing conditions.

ORCHID GERNERA	TIME TO MATURITY (MONTHS)	ORCHID GENERA	TIME TO MATURITY (MONTHS)
Bulbophyllum	3	Laelia	9
Brassia	9	Masdevallia	3.5
Calanthe	4	Miltonia	9
Catasetum	10	Odontoglossum	7
Cattleya	11	Oncidium	9
Coelogyne	13	Paphiopedilum	10
Cymbidium	10	Phaius	7.5
Cypripedium	3.5	Phalaenopsis	6
Dendrobium	12	Spathoglottis	1.5
Encyclia	8	Stanhopea	7
Epidendrum	3.5	Vanda	20

Immature (Green) Capsule Disinfection

1. Soak the immature (green) seed capsule in 100% bleach solution for 30 minutes.
2. Dip the capsule in isopropyl alcohol or ethanol for 5-10 seconds. Remove the capsule from the alcohol and carefully flame off the excess alcohol.
3. Under aseptic conditions, using a sterile knife or scalpel, open the capsule and scrape out the seed.
4. Carefully layer the seed over the surface of the culture medium. Seal all culture vessels. These vessels are now your mother flasks.

Mature (Dry) Seed Disinfection

1. Collect seed and place in a small flask or bottle.
2. Prepare a solution containing 5-10% commercial bleach containing a few drops (2 drops/100 ml) of Tween 20 (Product No. P720).
3. Add the bleach solution to the flask or bottle. Swirl the flask or bottle containing the seed and bleach.
4. Sterilize the seed in the manner described in Step 3 for 5-10 minutes.
5. Remove the bleach solution and rinse the seed with sterile tissue culture grade water (Product # W783).
6. Transfer the seed to sterile culture medium, and seal all culture vessels. These vessels are now your mother flasks.

PhytoTechnology Laboratories®

PO Box 12205; Shawnee Mission, KS 66282-2205

Phone: 1-888-749-8682 or 1-913-341-5343; Fax: 1-888-449-8682 or 1-913-341-5442

Web Site: www.phytotechlab.com

© 2009 PhytoTechnology Laboratories®

Replanting Seedlings

1. It may take anywhere from 1 month up to 9 months for the seed to begin to germinate. Approximately 30 to 60 days after germination begins, it will be necessary to transfer the seedlings to fresh medium for continued growth.
2. Prepare an orchid maintenance/ replate medium, such as P748 for epiphytic orchids or T849 for terrestrial orchids.
3. Under aseptic conditions, transfer the seedling from the mother flask to the flask containing the fresh medium. You should place the seedling about ¼" apart on the medium.
4. Allow the seedlings to continue to grow and develop. Root formation generally begins when the plant has 2-3 leaves. Continue to transfer the seedlings to fresh media every 30-60 days, increasing the spacing between the plants with each transfer. When the flask is ready for transfer to a community pot in the greenhouse, most flasks should have 15 to 25 plants depending upon the species.
5. Transfer the plants into a community pot using a finely ground orchid mix.

ORCHID STEM PROPAGATION METHODS

1. Remove any flowers that may remain on the flower stalk. Use clean, healthy, vigorous flower stalks with buds in their nodes. Stalks on which only a few flowers have bloomed are best. Avoid old flower stalks.
2. Wash the flower stalk under running tap water for 5 minutes.
3. Prepare a 10% chlorine bleach solution and add 2-3 drops of Tween 20 (Product No. P720) to this solution.
4. Section the flower stalk into smaller pieces by using a clean razor blade or scalpel and cutting between the nodes. Cut the flower stalk into approximately 13 – 20 mm ($\frac{1}{2}$ – $\frac{3}{4}$ "") sections leaving about 6 mm ($\frac{1}{4}$ "") below the node and the remainder above the node.
5. Place the nodal section in the bleach solution (from Step 3) for 15 minutes. Swirl the solution every 2-3 minutes.
6. After surface sterilizing, discard the bleach solution, and then under aseptic conditions, carefully remove the bract from around the node.
7. Prepare a 5% chlorine bleach solution and add 2-3 drops of Tween 20 (Product No. P720) to this solution.
8. Once all of the bracts have been removed, surface sterilize the nodes in the 5% bleach solution prepared in Step 7. Keep in this solution for 10 min, swirling the solution every 2-3 min.
9. Remove all of the bleach solution and rinse the nodes with sterile distilled water. Rinse by pouring the water over the nodes, swirling, then pour off the water. Repeat this step three times.
10. Under sterile conditions, remove approximately 3 mm ($\frac{1}{8}$ "") from each end of the nodal sections using a clean, sterile scalpel or razor. All tools should be dipped frequently in alcohol and flamed with an alcohol lamp (Product No. B876), or heated in a glass bead sterilizer to maintain sterility.
11. Transfer the nodal section to the culture vessels containing Orchid Multiplication Medium (Product No. O753). Insert the longer portion of the nodal section into the medium at a slight angle to just below the bud. This should result in the emerging shoot pointing upwards.
12. Most shoots will generally appear within one month and they are ready for replating after about 60 days.
13. Many nodes exude phenolic compounds into the media which may turn the media dark brown to black. This phenolic exudation will kill the nodes if you do not replate them to fresh media. The use of media containing charcoal will reduce the required frequency of replating to remove phenolics as the charcoal adsorbs and binds the phenolic compounds.
14. Replate onto Orchid Maintenance Medium (Product No. P748) and allow the plantlets to continue to develop and root. Roots will begin to appear after 2 or 3 leaves have been produced.

PhytoTechnology Laboratories®

PO Box 12205; Shawnee Mission, KS 66282-2205

Phone: 1-888-749-8682 or 1-913-341-5343; Fax: 1-888-449-8682 or 1-913-341-5442

Web Site: www.phytotechlab.com

© 2009 PhytoTechnology Laboratories®

ORCHID MEDIA PREPARATION INSTRUCTIONS

Powdered media are extremely hygroscopic and must be protected from atmospheric moisture. If possible, the entire contents of each package should be used immediately after opening. Media stored at 2-6° C and tightly sealed should last 2-3 years, depending on how often and for how long the medium bottle is open. Preparing the medium in a concentrated form is not recommended as some salts in the medium may precipitate and affect shelf life and storage conditions. The basic steps for preparing the culture medium:

1. Measure out approximately 90% of the required final volume of tissue culture grade water (Product No. W783), e.g. 900 ml for a final volume of 1000 ml. Select a container twice the size of the final volume.
2. While stirring the water, add the powdered medium and stir until completely dissolved. Media containing charcoal, fruit extracts, and/or agar will not completely dissolve.
3. Rinse the container that the medium was packaged in with a small volume of tissue culture grade water to remove traces of the powder. Add to the solution in Step 2.
4. Add desired heat stable supplements (e.g., sucrose, gelling agent, vitamins, auxins, cytokinins, etc.). (**Orchid media B142, B141, M551, P723, P748, P785, O753, T849, V895, F522, M579, and P656 are complete media and generally do not require the addition of any other components.**)
5. Add additional tissue culture grade water (Product # W783) to bring the medium to the final volume.
6. While stirring, determine and adjust, if necessary, the medium to desired pH using NaOH, HCl, or KOH. A pH of 5.2 to 5.4 is recommended for most orchid media. For small labs or home hobbyists, pH can be adjusted by using baking soda to raise the pH and vinegar to lower the pH of the medium.
7. If a gelling agent is used, heat until the solution is clear or transparent. Heating may be required to bring powders into solution.
8. Dispense the medium into the culture vessels before (or after) autoclaving according to your application. Add heat labile constituents after autoclaving.
9. Sterilize the medium in a validated autoclave at 1 kg/cm² (15 psi), 121°C, for the time period described under the section titled "Sterilization of Media".
10. Allow medium to cool and solidify prior to use.

STERILIZATION OF MEDIA

Plant tissue culture media are generally sterilized by autoclaving at 121°C and 1 kg/cm² (15 psi). Media can be sterilized in either an autoclave or pressure cooker with similar results. Recently, the use of the microwave oven has also been shown to be successful at sterilizing media. The time required for sterilization depends upon the volume of medium in the vessel. The minimum time required for sterilization of different volumes of medium are listed below. It is advisable to dispense medium in small aliquots whenever possible as many media components are broken down by prolonged exposure to heat. Times for sterilizing in a microwave are based on using a 1000-watt microwave with a turntable for even distribution of heat. The times required for sterilization may vary depending upon the model of the microwave, power wattage, and the number of vessels in the microwave.

MINIMUM STERILIZATION TIME FOR PLANT TISSUE CULTURE MEDIA

Volume of Medium per Vessel (mL)	Minimum Autoclaving Time ^a (min.)	Minimum Microwaving Time ^b (min.)
25	15-20	4-6
50	25	6-8
100	28	8-10
250	31	10-12
1000	40	NR
2000	48	NR
4000	63	NR

^a **Minimum Autoclaving Time** includes the time required for the liquid volume to reach the sterilizing temperature (121° C) and 15 min at 121°C (Burger, 1988). Times may vary due to differences in autoclaves. Validation with your autoclave or pressure cooker is recommended.

^b **Minimum Microwaving Time** includes the time require for the liquid volume to reach a temperature of 121° C and remain at this temperature for a period of 3-4 minutes. Validation with your microwave is recommended.

REFERENCE:

Lucke, E. 1971. Zur Samenkeimung Mediterraner Ophrys. Die Orchidee 22:62-65. Cited by a number of references including: Plant Cell and Tissue Culture, IK Vasil and TA Thorpe, eds. Kluwer Academic Publishers, 1994.

PhytoTechnology Laboratories®

PO Box 12205; Shawnee Mission, KS 66282-2205

Phone: 888-749-8682 (USA/Canada) or 1-913-341-5343 Fax: 888-449-8682 (USA/Canada) or 1-913-341-5442

Web Site: www.phytotechlab.com

© 2009 PhytoTechnology Laboratories®

ORCHID MEDIA GUIDE

Procedure	Product No.	Product Description	Comments
Seed Sowing— Epiphytic Orchids	P723	Orchid Seed Sowing Medium w/ Agar	Complete medium with charcoal and gelling agent. Also can be used for terrestrial orchid seed germination.
	K400	Knudson C Orchid Medium	Low salt formulation. Requires the addition of gelling agent.
	V505	Vacin and Went Modified Basal Salt Mixture	Low salt formulation. Requires the addition of vitamins, sucrose, and gelling agent.
	V882	Vacin & Went Orchid Medium	Low salt formulation. Requires the addition of sucrose and gelling agent.
	V891	Vacin & Went Modified Basal Salts	Low salt formulation. Requires the addition of gelling agent.
	V895	Vacin and Went Modified Basal Salt Medium	Low salt formulation. Complete medium. Does not contain charcoal.
Seed Sowing— Terrestrial Orchids	B141	BM-1 Orchid Medium	Complete medium. Does not contain charcoal. Organic nitrogen based medium.
	M551	Malmgren's Modified Terrestrial Orchid Medium	Complete medium. Organic nitrogen based media.
	T849	Terrestrial (<i>Cypripedium</i>) Orchid Medium	Complete medium. Does not contain charcoal. Some species may require the addition of 1-2 mg/L of kinetin for best results. Inorganic nitrogen based media.
	F522	Fast Terrestrial Orchid Medium	Complete Medium. Does not contain charcoal. Contains both sucrose and fructose.
	T839	Terrestrial (<i>Cypripedium</i>) Orchid Medium	Complete medium. Does not contain charcoal. Formulation without NH ₄ NO ₃ .
Stem Props (<i>Phalaenopsis</i> and other species)	O753	Orchid Multiplication Medium w/Agar	Complete medium.
	P793	Orchid Multiplication Medium	Requires the addition of gelling agent.
	M507	Murashige Cattleya Orchid Multiplication Medium	Best if used at ¼ to ½ strength. May need to be supplemented with 1-2 mg/L of either BA or kinetin.
Clonal Propagation & Multiplication	P793	Orchid Multiplication Medium	Use at ¼ to ½ strength for best results.
	M507	Murashige Cattleya Orchid Multiplication Medium	Best if used at ¼ to ½ strength. May need to be supplemented with 1-2 mg/L of either BA or kinetin.
	K400	Knudson C Orchid Medium	Low salt formulation. Requires the addition of gelling agent.
	V505	Vacin and Went Modified Basal Salt Mixture	Low salt formulation. Requires the addition of vitamins, sucrose, and gelling agent.
	V882	Vacin & Went Orchid Medium	Low salt formulation. Requires the addition of sucrose and gelling agent.
	V891	Vacin & Went Modified Basal Salts	Low salt formulation. Requires the addition of gelling agent.
Replanting	P748	Orchid Maintenance/Replate Medium w/Banana	Complete medium. Works well with <i>Phalaenopsis</i> , <i>Cattleya</i> , <i>Dendrobium</i> , and similar species.
	P785	Orchid Replate Medium	Complete medium. Works well with <i>Cattleya</i> and similar species.
	P668	Orchid Maintenance Medium w/Charcoal	Requires the addition of gelling agent. Should be supplemented with either banana powder or coconut water. Use at ¼ to ½ strength for best results with some species.
	O156	Orchid Maintenance Medium w/Banana and Charcoal	Requires the addition of gelling agent.
	O139	Orchid Maintenance Medium w/out Charcoal	Requires the addition of gelling agent. Should be supplemented with either banana powder or coconut water.
	B142	BM-2 Orchid Medium	Complete medium for terrestrial orchids. May work well with some <i>Paphiopedilum</i> and <i>Phragmipedium</i> species and hybrids. The addition of banana powder, pineapple powder, and/or coconut water may be beneficial.
	M579	Mitra Replate/Maintenance Medium	Complete medium. Contains charcoal. May work well with some <i>Vanda</i> and <i>Dendrobium</i> species and hybrids. The addition of coconut water may be beneficial.
	P656	PhytoTech Phalaenopsis Replate Medium	Complete medium. Contains charcoal. Works well with most <i>Phalaenopsis</i> species and hybrids, and related species and hybrids. The addition of coconut water may be beneficial.

PhytoTechnology Laboratories®

PO Box 12205; Shawnee Mission, KS 66282-2205

Phone: 888-749-8682 (USA/Canada) or 1-913-341-5343 Fax: 888-449-8682 (USA/Canada) or 1-913-341-5442

Web Site: www.phytotechlab.com

© 2009 PhytoTechnology Laboratories®

Product No.	Product Description
A111	AGAR Micropropagation/Plant Tissue Culture Grade Powder Plant Tissue Culture Tested
A296	AGAR (Agar-Agar; Gum Agar) Bacteriological Grade Powder Plant Tissue Culture Tested
A133	AGARGELLAN A blend of agar and Gelrite. Plant Tissue Culture Tested
B852	BANANA POWDER A mixture of Natural Banana Puree and Maltodextrin. Plant Tissue Culture Tested
C325	CHARCOAL, ACTIVATED, ACID WASHED Plant Tissue Culture Tested
C195	COCONUT WATER Natural, No Additives Plant Tissue Culture Tested
G434	GELLAN GUM CultureGel™ type I – Biotech Grade; White to cream free flowing powder; trans: 85%+ Gelrite equivalent GELRITE® is a registered trademark of Kelco. Plant Tissue Culture Tested
G386	D-GLUCOSE, ANHYDROUS ACS Reagent Plant Tissue Culture Tested
I364	INDOLE-3-ACETIC ACID SOLUTION (1mg/mL) (IAA; Heteroauxin) Plant Tissue Culture Tested
I460	INDOLE-3-BUTYRIC ACID SOLUTION (1mg/mL) (IBA; 4-[3-Indolyl]butyric Acid) Plant Tissue Culture Tested
K424	KEIKI PASTE Plant Tissue Culture Tested
K483	KINETIN SOLUTION (1mg/mL) (6-Furfurylaminopurine) Plant Tissue Culture Tested
N605	α-NAPHTHALENEACETIC ACID SOLUTION (1mg/mL) (NAA; 1-Naphthaleneacetic Acid) Plant Tissue Culture Tested
P775	PEPTONE Type 1 Enzymatic Digest From Meat Plant Tissue Culture Tested

Product No.	Product Description
P780	PEPTONE, GLYSATE From Gelatin Plant Tissue Culture Tested
P862	PINEAPPLE POWDER Dried Pineapple Puree w/Maltodextrin Use at 5-30 g/L Plant Tissue Culture Tested
S391	SUCROSE (α-D-Glucopyranosyl-β-D-fructofuranoside; Saccharose) Plant Tissue Culture Tested
T872	TOMATO POWDER Dried Tomato Puree w/Maltodextrin Plant Tissue Culture Tested

Product No.	Orchid Kit Description
O799	ORCHID SEED SOWING KIT, EPIPHYTIC ORCHIDS Contains: P723 – Orchid Seed Sowing Medium P748 – Orchid Replate Medium P785 – Orchid Replate Medium C913 – Culture Vessels F951 – Forceps P959 – pH Indicator Strips S963 – Scalpel S971 – Scalpel Blades Instruction Manual
O788	ORCHID SEED SOWING KIT, TERRESTRIAL ORCHIDS Contains: B141 – BM-1 Orchid Seed Sowing Medium B142 – BM-2 Orchid Medium M551 – Malmgren's Modified Terrestrial Orchid Medium T849 – Terrestrial Orchid Medium C913 – Culture Vessels F951 – Forceps P959 – pH Indicator Strips S963 – Scalpel S971 – Scalpel Blades Instruction Manual
O775	ORCHID STEM PROPAGATION KIT Contains: P748 – Orchid Replate Medium B141 – BM-1 Orchid Seed Sowing Medium B142 – BM-2 Orchid Medium O753 – Orchid Multiplication Medium C913 – Culture Containers F951 – Forceps P959 – pH Indicator Strips S963 – Scalpel S971 – Scalpel Blades Instruction Manual

PhytoTechnology Laboratories®

PO Box 12205; Shawnee Mission, KS 66282-2205

Phone: 888-749-8682 (USA/Canada) or 1-913-341-5343 Fax: 888-449-8682 (USA/Canada) or 1-913-341-5442

Web Site: www.phytotechlab.com

© 2009 PhytoTechnology Laboratories®

Product No.	Product Description
A007	SEALING FILM Clear PVC; 4.5 cm W x 150 m L
B939	BEAKERS, GRADUATED, GRIFFIN PMP, AUTOCLAVABLE 2000 mL
B960	BEAKERS, GRADUATED, GRIFFIN PMP, AUTOCLAVABLE 4000 mL
C093	CULTURE VESSEL Clear Polypropylene, w/ Lid 4-5/8"D x 2-7/8"H, Autoclavable
C168	CLEAR-CON™ CULTURE VESSEL Clear Polystyrene; NOT Autoclavable 68 mm D x 110 mm H Pre-sterilized by γ-Irradiation
C944	CLEAR-CON™ CULTURE VESSEL Clear Polystyrene; NOT Autoclavable 68 mm D x 68 mm H Pre-sterilized by γ-Irradiation
C215	PHYTOCON™-16 CULTURE VESSEL Clear Polypropylene, w/ Lid 4-1/2"D x 2-3/4"H Autoclavable
C532	CULTURE VESSEL Clear Polypropylene, w/ Lid 5-5/16"D x 3-1/4"H Autoclavable
C932	CULTURE VESSEL Clear Polypropylene, w/ Lid 4-5/8"D x 5 1/2 "H, Autoclavable
C032	CULTURE BOTTLE, GLASS, 32 oz (964 mL); Milk bottle; w/logo & graduation marks
F934	FLASKS, ERLLENMEYER, 125 mL, WIDE MOUTH Kimax

Product No.	Product Description
F979	FLASKS, ERLLENMEYER, 250 mL, WIDE MOUTH Kimax
F980	FLASKS, ERLLENMEYER, 500 mL, WIDE MOUTH Kimax
F985	FLASK, ERLLENMEYER 1000 mL, Wide Mouth
F986	FLASK, ERLLENMEYER 2000 mL, Wide Mouth
S981	STOPPER, RUBBER, No. 6½, ONE HOLE
S983	STOPPER, RUBBER, No. 8, ONE HOLE
S984	STOPPER, RUBBER, No. 10, ONE HOLE
F950	FORCEPS, DRESSING, 6" 2.4 cm
F951	FORCEPS, DRESSING, 8" 3.1 cm
F952	FORCEPS, DRESSING, 10" 3.9 cm
F953	FORCEPS, DRESSING, 12" 4.7 cm
F955	FORCEPS, CURVED, 6" 2.4 cm
F956	FORCEPS, CURVED, 8" 3.1 cm
F957	FORCEPS, BAYONET 8.25" Length (21 cm)
P959	pH INDICATOR STRIPS 0-14 pH Range
S970	SCALPEL BLADE, No. 10 Sterile Carbon Steel; Individually Wrapped
S971	SCALPEL BLADE, No. 11 Sterile Carbon Steel; Individually Wrapped
S963	SCALPEL HANDLE, No. 3 5" Length (2.0 cm)
S973	SCALPEL HANDLE, No. 3L 8" Length (3.1 cm)

Media Recommendation Note

The media recommendations provided in this document are all that are currently available from PhytoTechnology Labs. We regret that we are unable to provide media recommendations for genera not listed.

If you have personal experience successfully using a *PhytoTech* medium on a genus/species not listed we welcome your writing and informing us of it. The same is true if you see a reference citing a medium successfully used on a genus not listed. Please, do not call us with recommendations; we must receive them in writing.

Please email your recommendation(s) to tech@phytotechlab.com or mail it to the address below.

We will periodically update this document with the new information we receive.

Rev. 10/2009

PhytoTechnology Laboratories®

PO Box 12205; Shawnee Mission, KS 66282-2205

Phone: 888-749-8682 (USA/Canada) or 1-913-341-5343 Fax: 888-449-8682 (USA/Canada) or 1-913-341-5442

Web Site: www.phytotechlab.com

© 2009 PhytoTechnology Laboratories®